

Max Frank GmbH & Co. KG

Mitterweg 1
D-94339 Leiblfling
Germany

Tel: 00 49 9427/189-0 Fax: 00 49 9427/1588
e-mail: info@maxfrank.de
website: www.maxfrank.com



Agrément Certificate
08/4602
Product Sheet 1

MAX FRANK GmbH & CO KG EGCOBOX CANTILEVER CONNECTION SYSTEM

EGCOBOX CANTILEVER CONNECTION SYSTEM

PRODUCT SCOPE AND SUMMARY OF CERTIFICATE

This Certificate relates to the EgcoBOX Cantilever Connection System for use in reinforced concrete structures to form a thermal break between balcony and internal floor, whilst transferring load and maintaining full structural integrity.

AGRÉMENT CERTIFICATION INCLUDES:

- factors relating to compliance with Building Regulations where applicable
- factors relating to additional non-regulatory information where applicable
- independently verified technical specification
- assessment criteria and technical investigations
- design considerations
- installation guidance
- regular surveillance of production
- formal three-yearly review.

KEY FACTORS ASSESSED

Structural aspects — the products have adequate strength to resist the loads associated with permanent loading (see section 5).

Thermal performance — The products contribute towards the overall thermal insulation of the building envelope in reducing cold bridging between internal and external elements (see section 6).

Behaviour in relation to fire — either the fire protection plates incorporated in the products or the use of mineral wool as the insulation core will provide up to 90 minutes resistance (see section 8).

Durability — under the normal service conditions the products will have a service life of at least 60 years (see section 10).

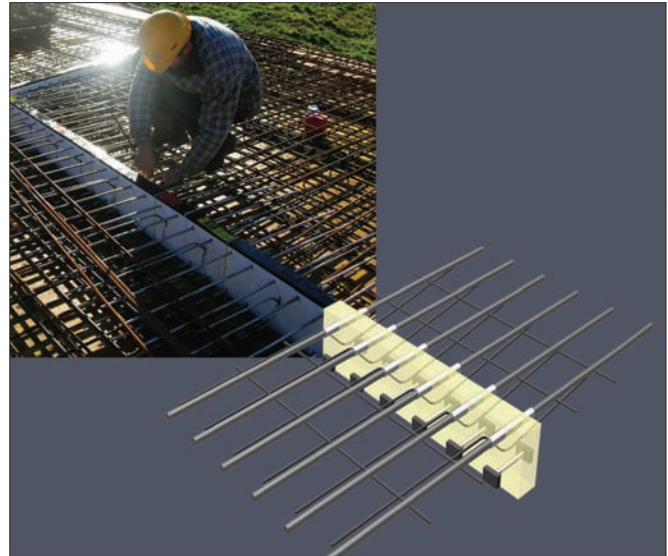

The BBA has awarded this Agrément Certificate to the company named above for the products described herein. These products have been assessed by the BBA as being fit for their intended use provided they are installed, used and maintained as set out in this Certificate.

On behalf of the British Board of Agrément

Brian Chamberlain
Head of Approvals — Engineering

Greg Cooper
Chief Executive

Date of First issue: 22 January 2008

The BBA is a UKAS accredited certification body — Number 113. The schedule of the current scope of accreditation for product certification is available in pdf format via the UKAS link on the BBA website at www.bbacerts.co.uk

Readers are advised to check the validity and latest issue number of this Agrément Certificate by either referring to the BBA website or contacting the BBA direct.

British Board of Agrément
Bucknalls Lane
Garston, Watford
Herts WD25 9BA

©2009

tel: 01923 665300
fax: 01923 665301
e-mail: mail@bba.star.co.uk
website: www.bbacerts.co.uk

Regulations

In the opinion of the BBA, the Egcoibox Cantilever Connection System, if used in accordance with the provisions of this Certificate, will meet or contribute to meeting the relevant requirements of the following Building Regulations:



The Building Regulations 2000 (as amended) (England and Wales)

Requirement:	A1	Loading
Comment:		The products have sufficient strength and stiffness to sustain and transmit the design loads in accordance with sections 5.2 to 5.6 of this Certificate.
Requirement:	B3(1)	Internal fire spread (structure)
Comment:		Either the fire protection plates incorporated in the products or the use of mineral wool as the insulation core will provide up to 90 minutes fire resistance. See section 8.3 of this Certificate.
Requirement:	L1(a)(i)	Conservation of fuel and power
Comment:		The products contribute towards the overall thermal insulation of the building envelope in reducing cold bridging between internal and external elements. See sections 6.1 and 6.2 of this Certificate.
Requirement:	Regulation 7	Materials and workmanship
Comment:		The products are acceptable. See section 10.1 and the <i>Installation</i> part of this Certificate.



The Building (Scotland) Regulations 2004 (as amended)

Regulation:	8(1)(2)	Fitness and durability of materials and workmanship
Comment:		The products comply with the requirements of this Regulation. See sections 9 and 10.1 and the <i>Installation</i> part of this Certificate.
Regulation:	9	Building standards — construction
Standard:	1.1(a)(b)	Structure
Comment:		Reinforced concrete walls and floors incorporating the products have sufficient strength and stiffness to sustain and transmit the design loads in accordance with sections 5.2 to 5.6 of this Certificate, with reference to clauses 1.1.1 ⁽¹⁾⁽²⁾ to 1.1.3 ⁽¹⁾⁽²⁾ .
Standard:	2.3	Structural protection
Comment:		Either the fire protection plates or the use of mineral wool as the insulation core will provide up to 90 minutes resistance (medium), with reference to clauses 2.3.1 ⁽¹⁾⁽²⁾ to 2.3.3 ⁽¹⁾⁽²⁾ . See section 8.3 of this Certificate.
Standard:	6.2	Building insulation envelope
Comment:		The products contribute towards the overall thermal insulation of the building envelope in reducing cold bridging between internal and external elements, with reference to clauses 6.2.0 ⁽¹⁾⁽²⁾ , 6.2.3 ⁽¹⁾ and 6.2.4 ⁽²⁾ . See sections 6.1 and 6.2 of this Certificate. (1) Technical Handbook (Domestic). (2) Technical Handbook (Non-Domestic).



The Building Regulations (Northern Ireland) 2000 (as amended)

Regulation:	B2	Fitness of materials and workmanship
Comment:		The products are acceptable. See section 10.1 and the <i>Installation</i> part of this Certificate.
Regulation:	B3(2)	Suitability of certain materials
Comment:		The products are acceptable. See section 9 of this Certificate.
Regulation:	D1	Stability
Comment:		The products have sufficient strength and stiffness to sustain and transmit the design loads in accordance with sections 5.2 to 5.6 of this Certificate.
Regulation:	E4(1)	Internal fire spread — Structure
Comment:		Either the fire protection plates incorporated in the products or the use of mineral wool as the insulation core will provide up to 90 minutes fire resistance. See section 8.3 of this Certificate.
Regulation:	F2	Conservation measures
Comment:		The products contribute towards the overall thermal insulation of the building envelope in reducing cold bridging between internal and external elements. See sections 6.1 and 6.2 of this Certificate.

Construction (Design and Management) Regulations 2007

Construction (Design and Management) Regulations (Northern Ireland) 2007

Information in this Certificate may assist the client, CDM co-ordinator, designer and contractors to address their obligations under these Regulations.

See section: 2 *Delivery and site handling* and 11 *General*.

Non-regulatory Information

NHBC Standards 2008

NHBC accepts the use of the Egcoibox Cantilever Connection System, when installed and used in accordance with this Certificate, in relation to *NHBC Standards*, Chapter 7.1, *Flat roofs and balconies*.

Zurich Building Guarantee Technical Manual 2007

In the opinion of the BBA, the Egccobox Cantilever Connection System, when installed and used in accordance with this Certificate, satisfies the requirements of the *Zurich Building Guarantee Technical Manual, Section Superstructure, Sub-section Flat roofs – General – balconies*.

General

This Certificate relates to the Egccobox Cantilever Connection System for use in reinforced concrete balconies to domestic and commercial structures.

Technical Specification

1 Description

1.1 The Egccobox Cantilever Connection System products allow full transfer of load from an external balcony into the main structure whilst providing a thermal break to reduce heat loss to the outside. The products are used primarily in reinforced concrete structures and are designed to form integrally with the floor construction. The range of products are described in Table 1 and illustrated in Figure 1.

Table 1 Products within the range

Products	Type of element ⁽¹⁾	Depth of slab (mm)
Egccobox Mz-D	Standard elements to transfer shear forces and bending moments	160 – 250
Egccobox Mz-D-F	Standard elements to transfer shear forces and bending moments. Partitional model especially for precasting plants	160 – 250
Egccobox Mz-HV	Standard elements to transfer shear forces and bending moments; for stepped balconies	160 – 250
Egccobox Mz ±	Elements for changing loads (positive and negative M and V)	160 – 250
Egccobox Mz-G	Standard elements to transfer shear forces and bending moments incorporating thrust blocks	160 – 250
Egccobox Vz	Shear force elements to only transfer shear forces	160 – 250
Egccobox Vz ±	Shear force elements for changing loads (positive and negative shear forces)	160 – 250
Egccobox Vz-DK	Short elements to transfer shear forces	160 – 250
Egccobox Vz-DK ±	Short elements to transfer positive and negative shear forces	160 – 250
Egccobox Mz-Eck	Corner elements for inside or outside corners	160 – 250
Egccobox F	Elements for parapets horizontal connection	160 – 250
Egccobox A	Elements for parapet walls	160 – 250
Egccobox O	Elements for cantilevered brackets	160 – 250
Egccobox S	Elements for major loads	400 – 500
Egccobox W	Wall elements	1500 – 2500 ⁽²⁾

(1) All elements are 1000 mm long.

(2) Wall heights.

1.2 Components include:

- high density expanded polystyrene insulation to BS EN 13163 : 2001, 50 mm to 120 mm wide by 160 mm to 250 mm deep
- Mineral wool insulation to BS EN 13162 : 2001
- ribbed steel tensile reinforcing bars (BST 500S to DIN 488-1 : 1984)
- 1 mm thick stainless steel sleeve (1.4301 or 1.4571 to BS EN ISO 1127 : 1997)
- ribbed stainless steel shear and compression reinforcement to BS EN 10088-3 : 2005 (tensile strength 500 Nmm⁻²)
- two-component resin
- 50 mm by 30 mm structural steel (grade S235 JRG1) compression thrust blocks welded to stainless steel ribbed reinforcement by applying a continuous fillet weld around the circumference of the bar.

Tensile reinforcement

1.3 Tensile forces are transferred by ribbed tensile steel reinforcing bars, which are protected by a stainless steel sleeve where the bars pass through the insulation (see Figure 1). The inside diameter of the sleeve is 2 mm wider than the nominal diameter of the reinforcement bar. The sleeve extends beyond the sides of the insulation (see Figure 1) by 60 mm to allow it to bond with the concrete. The area between the sleeve and the reinforcement is completely filled with a two-component resin.

Compression reinforcement

1.4 Compressive forces are transferred from the balcony to the floor construction by use of a steel-compression thrust block welded to stainless steel ribbed compression reinforcement, which passes through the insulation.

Figure 1 Product types

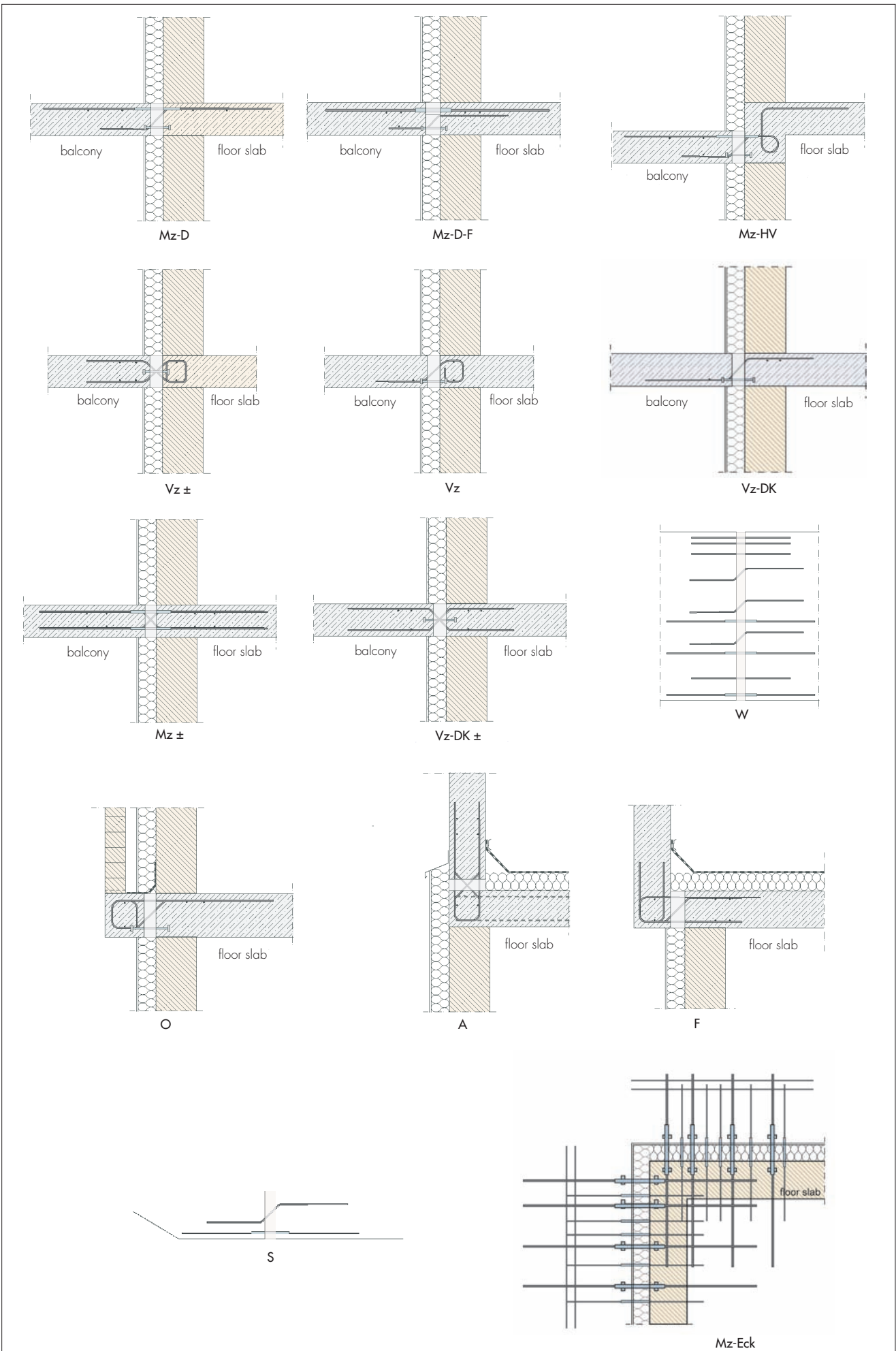

Shear reinforcement

1.5 Shear forces are resisted by ribbed stainless steel reinforcement passing diagonally through the insulation (see Figure 2).

1.6 The products within the range, incorporating some or all of the described components, are given in Table 1.

1.7 Accessories and fixings used in conjunction with the panels comprise:

- instruction label — attached to reinforcement of each element type
- fire protection plate — 15 mm thick, made from fibreglass cement-bonded board complying with DIN 4102-2 : 1977, top and bottom of damage protection channel using hot-melt adhesive
- damage protection channel — C-shaped black plastic, 1 mm thick, provided to top and bottom of products.

1.8 Quality control tests are carried out on the products to determine:

- dimensional accuracy
- geometry
- mechanical properties.

Figure 2 Reinforcement for shear resistance

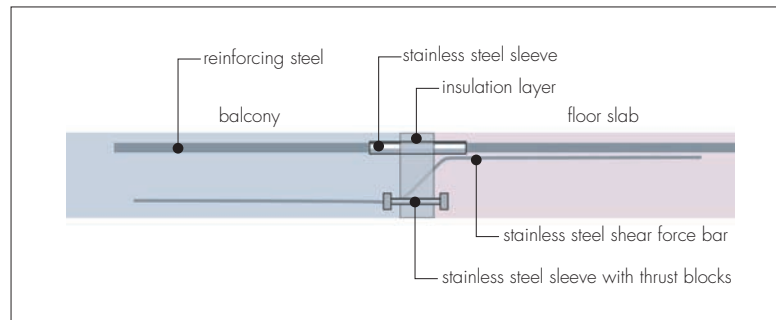

2 Delivery and site handling

Products within the range are normally supplied to order in palletised and shrink wrapped packages containing full or part orders. During off-loading care must be taken to avoid bending reinforcement or damaging the expanded polystyrene or mineral wool core. Packages must be stored away from direct sunlight and contact with solvents or other harmful chemicals should be avoided.

Assessment and Technical Investigations

The following is a summary of the assessment and technical investigations carried out on Egccobox Cantilever Connection System.

Design Considerations

3 Use

The range of products are for use in reinforced concrete balconies within domestic and commercial structures to form a thermal break between the balcony and internal floor and transfer load, and maintain full structural integrity.

4 Practicability of installation

The products can be installed by operatives familiar with the fixing of reinforcement. The operatives will need to be competent and appropriately trained and take account of the installation instructions provided with each product.

5 Structural aspects

5.1 The Egccobox range of products (see Table 1), when designed and installed in accordance with the Certificate holder's installation instructions, have the capability of transferring tensile, shear and compressive forces via the steel reinforcement and the compression elements through to the supporting structure.

5.2 The minimum strength of concrete that should be used in the balcony construction is 25 Nmm⁻² to 30 Nmm⁻². The supporting floor concrete strength must be at least 20 Nmm⁻².

5.3 The amount of concrete cover depends on the exposure conditions prevalent and fire resistance and must be in accordance with BS 8110-1 : 1997 or BS EN 1992-1-1 : 2004. The minimum concrete cover must be at least 30 mm from the outer edge.

5.4 The quantities of tensile and/or shear reinforcement to be provided within each of the products, to resist the balcony or other direct loads, must be calculated by a Structural Engineer in accordance with BS 8110-1 : 1997 or BS EN 1992-1-1 : 2004 (Eurocode 2). Tension reinforcement should be between 6 mm and 16 mm in diameter, and shear reinforcement between 6 mm and 16 mm in diameter. A minimum of three compression and shear reinforcing bars must be provided every 1 m length of each of the products.

5.5 A minimum of four tensile reinforcing rods should be provided per metre run or in accordance with the spacing requirements given in BS 8110-1 : 1997 or BS EN 1992-1-1 : 2004.

5.6 The anchor length of steel reinforcement should be in accordance with BS 8110-1 : 1997 or BS EN 1992-1-1 : 2004.

5.7 Site welding must not be undertaken under any circumstances.

5.8 The mechanism of structural resistance of the products is shown in Figure 3 in a framework model form. Structural analysis of individual balconies can be carried out using the framework models.

Figure 3 Framework models

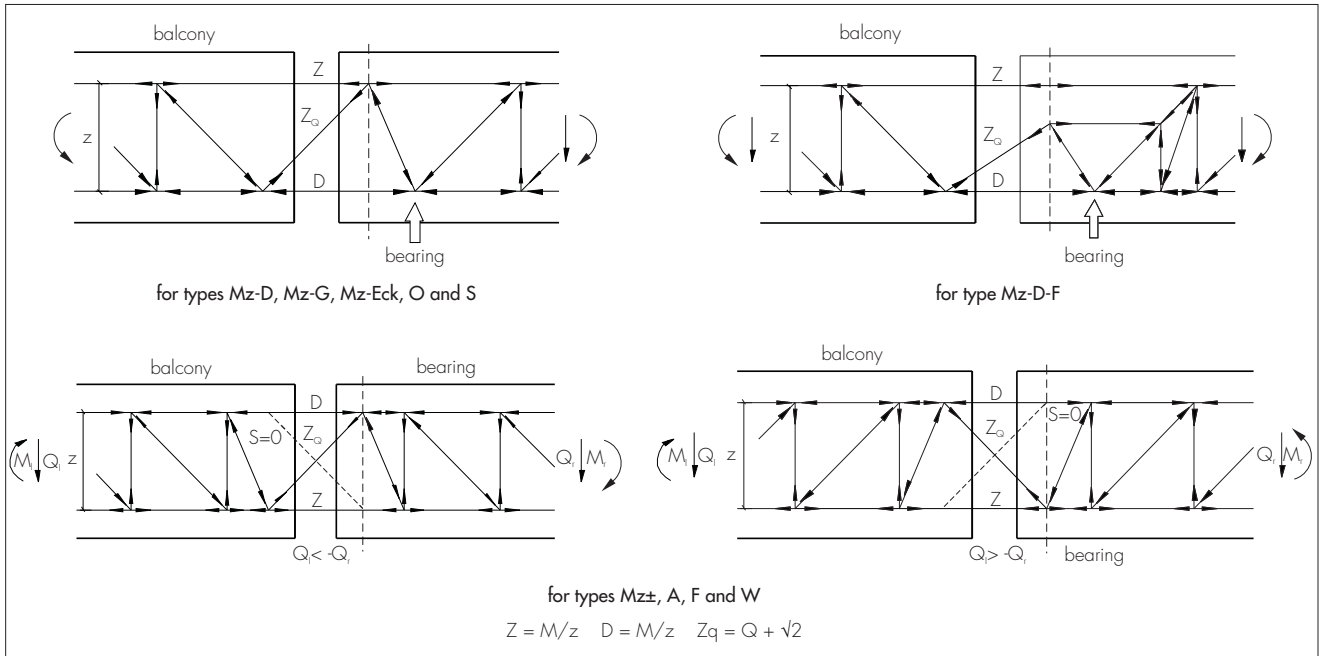

5.9 Tension reinforcement forming each of the products must remain straight and should not be bent.

5.10 Where an opening forms part of the balcony support, additional transverse reinforcement should be provided to compensate for the reduction in continuous support.

5.11 Ultimate tensile strength used in the product range is in accordance with DIN 1045-1 : 2008 and can be taken as 500 Nmm^{-2} . Ultimate tensile high-yield stainless steel ribbed reinforcement can also be taken to have an ultimate tensile strength of 500 Nmm^{-2} . Test result data can also be obtained from the Certificate holder to verify specified tensile resistance figures.

5.12 During construction an upwards camber should be provided to the balcony formwork in accordance with the Certificate holder's own design tables or by calculating the deflection by structural analysis.

6 Thermal performance



6.1 The product can contribute to the limiting of the heat loss around the junction between an external wall and a balcony by allowing the insulation to be maintained through any cavity present.

6.2 The psi (ψ) value and temperature factor for a specific construction should be determined in accordance with BRE Report (BRE 497 : 2007) *Conventions for calculating linear thermal transmittance and temperature factors* and compared to values given in BRE information Paper IP 1/06 *Assessing the effects of thermal bridging at junctions and around openings*. For example, using a computer model, the performance of the balcony connector within a wall construction of a 105 mm thick reinforced concrete inner leaf, insulation 80 mm thick (λ value of $0.40 \text{ Wm}^{-2}\text{K}^{-1}$), a 20 mm wide cavity and a 105 mm thick masonry external wall, when modelled with an internal surface resistance of $0.25 \text{ m}^2\text{KW}^{-1}$, was estimated to give a ψ value of $0.35 \text{ Wm}^{-2}\text{K}^{-1}$ and a temperature factor of 0.84. The thermal conductivity (λ) values given in Table 2 can be taken for the component parts of the system.

Table 2 Material properties

Material	Thermal conductivity ($\text{Wm}^{-1}\text{K}^{-1}$)
Mild steel	50
Stainless steel	17
Epoxy resin	0.2
Polystyrene	0.04

7 Condensation

7.1 The condensation risk associated with a particular construction should be assessed in accordance with BS 5250 : 2002. Additional ventilation may be required if the connector is to be used in situations where the internal relative humidity is expected to exceed 70% for any significant length of time.

7.2 Constructions should be appropriately vapour resistant to ensure the risk of interstitial condensation is minimised.

8 Behaviour in relation to fire

8.1 The use of the products, when incorporating top and bottom fire protection plates, will not introduce any additional hazard in respect of behaviour in a fire situation if installed in accordance with the Certificate holder's instructions.

8.2 The nominal cover to reinforcement should be that appropriate to 'mild' exposure in accordance with BS 8110-1 : 1997, Table 3.4 and Figure 3.2, or as required for fire resistance in accordance with BS 8110-2 : 1985, Section 4, whichever is the greater.



8.3 Either top and bottom fire protection plates or the use of mineral wool as the insulation core will provide a fire resistance of up to 90 minutes.

8.4 Test results have indicated that the products incorporating the fire protection plates, or when using mineral wool as the insulation core, are capable of achieving up to 90 minutes loadbearing capacity, 90 minutes integrity and 90 minutes insulation.

9 Maintenance



Once properly installed within the floor construction, the products should not require maintenance throughout their serviceable life. The fire plates, when installed, should be inspected periodically for damage and adhesion to the surrounding concrete, and replaced or repaired as necessary.

10 Durability



10.1 Balconies constructed with the Egco box range of products will have a service life of not less than 60 years.

10.2 Reinforcement, forming part of each product, should be provided with the nominal concrete cover as stated in BS 8110-1 : 1997, Table 3.3, to meet durability requirements, depending on conditions of exposure.

Installation

11 General

Installation instructions are provided by the Certificate holder. Width and depth measurements and direction of lay (in the form of an arrow pointing towards the balcony) are given on the label affixed to top of each product.

12 Procedure

The following procedure applies to the model type Mz-D:

- Top and bottom reinforcement is laid and fixed to standard detailing requirements, leaving sufficient space to insert the Egco box balcony connector.
- The balcony connector, with the top and bottom fire plates fitted, is seated within the reinforcement and its position checked for correct alignment and wired to the top and bottom reinforcement.
- A final position check is made prior to pouring concrete.
- During pouring, the concrete should be evenly distributed around the balcony connector. Care should be taken when using vibrators to avoid dislodging the balcony connector from its intended position.

Technical Investigations

13 Investigations

13.1 An examination was made of data relating to:

- advisory opinion on fire behaviour by IBMB⁽¹⁾
- thermal attributes by Gesellschaft für Ingenieurbau und Systementwicklung mbH
- structural calculations provided by the Certificate holder.

(1) Institut für Baustoffe, Massivbau und Brandschutz der Technischen Universität (Institute of building materials, concrete construction and fire protection), Braunschweig, Germany

13.2 The manufacturing process was assessed, including the methods adopted for quality control and details were obtained of the quality and composition of materials used.

13.3 A site visit was carried out to witness the installation process including construction of various reinforced balcony constructions, placement of the Egco box balcony connectors and general reinforcement and pouring of concrete.

Bibliography

BS 5250 : 2002 *Code of practice for control of condensation in buildings*

BS 8110-1 : 1997 *Structural use of concrete — Code of practice for design and construction*

BS 8110-2 : 1985 *Structural use of concrete — Code of practice for special circumstances*

BS EN 1992-1-1 : 2004 *Eurocode 2 : Design of concrete structures. General rules and rules for buildings*

BS EN 10088-1 : 2005 *Stainless steels — List of stainless steels*

BS EN 13162 : 2001 *Thermal insulation products for buildings — Factory made mineral wool (MW) products — Specification*

BS EN 13163 : 2001 *Thermal insulation products for buildings — Factory made products of expanded polystyrene (EPS) — Specification*

BS EN ISO 1127 : 1997 *Stainless Steel Tubes — Dimensions, tolerances and conventional masses per unit length*

DIN 488-1 : 1984 *Reinforcing steels; grades, properties, marking*

DIN 1045-1 : 2008 *Concrete, reinforced and prestressed concrete structures — Design and construction*

DIN 4102-2 : 1977 *Fire behaviour of building materials and building components; Building components; Definitions, requirements and tests*

Conditions of Certification

14 Conditions

14.1 This Certificate:

- relates only to the product/system that is named and described on the front page
- is granted only to the company, firm or person named on the front page — no other company, firm or person may hold or claim any entitlement to this Certificate
- is valid only within the UK
- has to be read, considered and used as a whole document — it may be misleading and will be incomplete to be selective
- is copyright of the BBA
- is subject to English law.

14.2 References in this Certificate to any Act of Parliament, Statutory Instrument, Directive or Regulation of the European Union, British, European or International Standard, Code of Practice, manufacturers' instructions or similar publication, are references to such publication in the form in which it was current at the date of this Certificate.

14.3 This Certificate will remain valid for an unlimited period provided that the product/system and the manufacture and/or fabrication including all related and relevant processes thereof:

- are maintained at or above the levels which have been assessed and found to be satisfactory by the BBA
- continue to be checked as and when deemed appropriate by the BBA under arrangements that it will determine
- are reviewed by the BBA as and when it considers appropriate.

14.4 In granting this Certificate, the BBA is not responsible for:

- the presence or absence of any patent, intellectual property or similar rights subsisting in the product/system or any other product/system
- the right of the Certificate holder to manufacture, supply, install, maintain or market the product/system
- individual installations of the product/system, including the nature, design, methods and workmanship of or related to the installation
- the actual works in which the product/system is installed, used and maintained, including the nature, design, methods and workmanship of such works.

14.5 Any information relating to the manufacture, supply, installation, use and maintenance of this product/system which is contained or referred to in this Certificate is the minimum required to be met when the product/system is manufactured, supplied, installed, used and maintained. It does not purport in any way to restate the requirements of the Health & Safety at Work etc Act 1974, or of any other statutory, common law or other duty which may exist at the date of this Certificate; nor is conformity with such information to be taken as satisfying the requirements of the 1974 Act or of any statutory, common law or other duty of care. In granting this Certificate, the BBA does not accept responsibility to any person or body for any loss or damage, including personal injury, arising as a direct or indirect result of the manufacture, supply, installation, use and maintenance of this product/system.