

FRANK | reinforcement systems





- Steel rebars: guaranteed rebendability BSt 500 WR based on DIN 488
- Bent over a 6x rebar diameter bending roller at the problematic, work-hardened rebending points, based on DIN 1045-1.
- Manufacture and dimensioning to DIN 1045-1 taking into account technical guidelines such as issued in the „Rebending Code of Practice of the German Concrete Association“ (DBV)
- Standardised structural analysis for all applications, calculation of transverse and shearing force resistance V_{Rd}
- Standard profile Stabox S „interlocked“ for calculation of transverse force bearing resistance V_{Rd}
- Special profile Stabox T „interlocked“ for the calculation of the transverse force resistance V_{Rd}
- Technical advice on areas of application and calculation tables can be found in our brochure „Reinforcement Systems“. Please also ask for Stabox design tables.

Dimensions of standard types

Standard stirrup versions

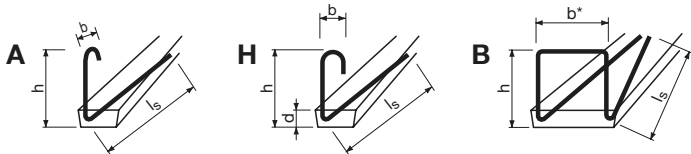

Number of stirrups and hooks for standard element length

s = 10 cm	12 pcs.
s = 15 cm	8 pcs.
s = 20 cm	6 pcs.

Standard dimensions

Steel \varnothing mm	Possible hook/stirrup shaping	Possible hook/stirrup spacing s cm	Element thickness d cm	Stirrup height h cm	Hook width b cm	Lap length l_s cm	Element length l m
8	A / H / B	10 / 15 / 20	3	15	4.8	30	1.25
10	A / H / B	10 / 15 / 20	3 – 4	15	6.0	38	1.25
12	A / H / B	10 / 15 / 20	4 – 5	17	7.2	46	1.25

Lap length l_s : according to DIN 1045-1, unless otherwise noted. *Stirrup width b = case width – 2 cm

Stabox

Standard single-row versions

	Art. no.	For wall thickness from cm	Type	Steel diameter mm	Stirrup spacing cm	Element length m	Pieces/pallet	Weight kg/pce.	Weight kg/pallet
	STA05A0810	9	5 A	8	10	1.25	120	3.91	490
	STA05A0815	9	5 A	8	15	1.25	120	2.98	377
	STA05A0820	9	5 A	8	20	1.25	120	2.51	321
	STA09A1010	13	9 A	10	10	1.25	120	6.27	773
	STA05A1015	9	5 A	10	15	1.25	120	4.55	566
	STA05A1020	9	5 A	10	20	1.25	120	3.69	463
	STA09A1210	13	9 A	12	10	1.25	120	8.64	1057
	STA09A1215	13	9 A	12	15	1.25	120	6.22	766
	STA05A1220	9	5 A	12	20	1.25	120	5.87	724
	STA05H0810	9	5 H	8	10	1.25	120	3.91	490
	STA05H0815	9	5 H	8	15	1.25	120	2.98	377
	STA05H0820	9	5 H	8	20	1.25	120	2.51	321
	STA09H1010	13	9 H	10	10	1.25	120	6.27	773
	STA05H1015	9	5 H	10	15	1.25	120	4.55	566
	STA05H1020	9	5 H	10	20	1.25	120	3.69	463
	STA09H1210	13	9 H	12	10	1.25	120	8.86	1083
	STA09H1215	13	9 H	12	15	1.25	120	6.37	784
	STA05H1220	9	5 H	12	20	1.25	120	5.87	724

*Please refer to chart „Dimensions of standard types“. The stirrup height may vary by 10 mm – 20 mm because of manufacturing and installation tolerances.

Stabox S

Standard twin-row types, steel case profile „interlocked“ where transverse force bearing resistance V_{Rd} is calculated

	Art. no.	For wall thickness from cm	Type	Steel diameter mm	Stirrup spacing cm	Element length m	Pieces/pallet	Weight kg/pce.	Weight kg/pallet	
	STA09B0815	13	9 B	8	15	1.25	120	4.39	547	
	STA09B0820	13	9 B	8	20	1.25	120	3.64	457	
	STA09B1015	13	9 B	10	15	1.25	120	6.78	834	
	STA09B1020	13	9 B	10	20	1.25	120	5.43	672	
	STA12B0810	16-18	12 B	8	10	1.25	120	6.30	776	
	STA12B0815	16-18	12 B	8	15	1.25	120	4.75	590	
	STA12B0820	16-18	12 B	8	20	1.25	120	3.98	498	
	STA12B1015	16-18	12 B	10	15	1.25	120	7.18	882	
	STA12B1020	16-18	12 B	10	20	1.25	120	5.80	716	
	STA12B1215	16-18	12 B	12	15	1.25	120	10.89	1327	
	STA14B0810	18-20	14 B	8	10	1.25	120	6.73	828	
	STA14B0815	18-20	14 B	8	15	1.25	120	5.16	639	
	STA14B0820	18-20	14 B	8	20	1.25	120	4.37	544	
	STA14B1015	18-20	14 B	10	15	1.25	120	7.70	944	
	STA14B1020	18-20	14 B	10	20	1.25	120	6.27	773	
	STA14B1215	18-20	14 B	12	15	1.25	120	8.65	1058	
	STA16B0810	20-23	16 B	8	10	1.25	120	6.89	847	
	STA16B0815	20-23	16 B	8	15	1.25	120	5.28	654	
	STA16B0820	20-23	16 B	8	20	1.25	120	4.47	556	
	STA16B1010	20-23	16 B	10	10	1.25	120	10.64	1297	
	STA16B1015	20-23	16 B	10	15	1.25	120	7.78	954	
	STA16B1020	20-23	16 B	10	20	1.25	120	6.35	782	
	STA16B1215	20-23	16 B	12	15	1.25	120	11.57	1408	
	STA16B1220	20-23	16 B	12	20	1.25	120	9.19	1123	
		STA19B0810	23-26	19 B	8	10	1.25	60	7.00	440
		STA19B0815	23-26	19 B	8	15	1.25	60	5.34	340
		STA19B0820	23-26	19 B	8	20	1.25	60	4.51	291
		STA19B1010	23-26	19 B	10	10	1.25	60	10.82	669
STA19B1015		23-26	19 B	10	15	1.25	60	7.89	493	
STA19B1020		23-26	19 B	10	20	1.25	60	6.42	405	
	STA19B1215	23-26	19 B	12	15	1.25	60	12.52	771	
	STA19B1220	23-26	19 B	12	20	1.25	60	10.09	625	
		STA22B0810	26-29	22 B	8	10	1.25	60	7.91	495
		STA22B0815	26-29	22 B	8	15	1.25	60	6.21	393
		STA22B0820	26-29	22 B	8	20	1.25	60	5.36	341
		STA22B1010	26-29	22 B	10	10	1.25	60	11.93	736
STA22B1015		26-29	22 B	10	15	1.25	60	8.89	553	
STA22B1020		26-29	22 B	10	20	1.25	60	7.37	462	
	STA22B1210	26-29	22 B	12	10	1.25	60	18.02	1101	
	STA22B1215	26-29	22 B	12	15	1.25	60	12.95	797	
	STA22B1220	26-29	22 B	12	20	1.25	60	10.41	645	
		STA25B0810	29	25 B	8	10	1.25	60	8.33	520
		STA25B0815	29	25 B	8	15	1.25	60	6.58	415
		STA25B0820	29	25 B	8	20	1.25	60	5.71	362
STA25B1010		29	25 B	10	10	1.25	60	12.44	767	
STA25B1015		29	25 B	10	15	1.25	60	9.32	579	
STA25B1020		29	25 B	10	20	1.25	60	7.76	486	
	STA25B1210	29	25 B	12	10	1.25	60	18.62	1137	
	STA25B1215	29	25 B	12	15	1.25	60	13.44	827	
	STA25B1220	29	25 B	12	20	1.25	60	10.85	671	

*Please refer to chart „Dimensions of standard types“.

The stirrup height may vary by 10 mm – 20 mm because of manufacturing and installation tolerances.

Rebending tools

Art. no.	For steel diameter mm	Identification colour
STARBW08	8	yellow
STARBW10	10	green
STARBW12	12	red

Please ensure that only suitable tools are used for rebending.

Stabox special design SA/SH

Art. no.: STASA/STASH

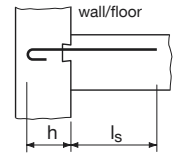
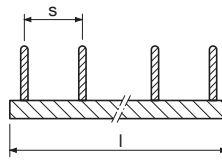
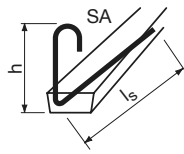
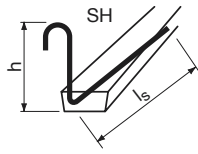

State only if required

Pos.	Steel \varnothing mm	Hook distance s (cm)	Lap length l_s (cm)	Hook height h (cm)		Quantity pcs.	Element length l (m)	Σ lin. m	Steel case	
									Width type ____	Depth t (cm)

Stabox special design SB

Art. no.: STASB

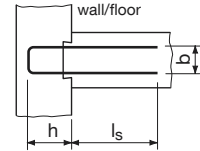
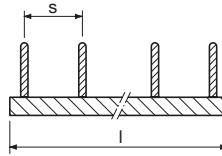
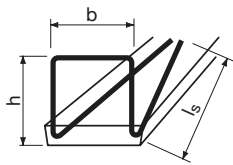

State only if required

Pos.	Steel \varnothing mm	Stirrup spacing s (cm)	Lap length l_s (cm)	Stirrup height h (cm)	Stirrup width b (cm)	Quantity pcs.	Element length l (m)	Σ lin. m	Steel case	
									Width type ____	Depth t (cm)

Stabox special design SD often used in connection with injection hose (water stop)

Art. no.: STASD

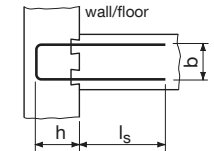
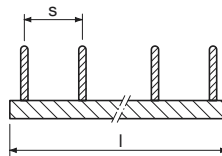
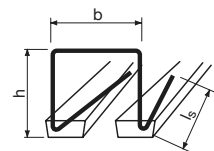

State only if required

Pos.	Steel \varnothing mm	Stirrup spacing s (cm)	Lap length l_s (cm)	Stirrup height h (cm)	Stirrup width b (cm)	Quantity pcs.	Element length l (m)	Σ lin. m	Steel case	
									Width type ____	Depth t (cm)

Stabox special design SG Lap joint on both sides

Art. no.: STASG

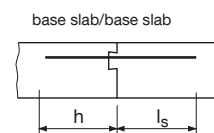
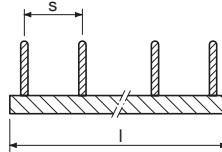
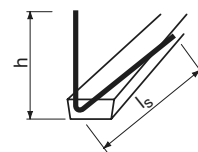

State only if required

Pos.	Steel \varnothing mm	Hook distance s (cm)	Lap length l_s (cm)	Hook height h (cm)		Quantity pcs.	Element length l (m)	Σ lin. m	Steel case	
									Width type ____	Depth t (cm)

Stabox special design SU for cantilevers **Art. no.: STASU**

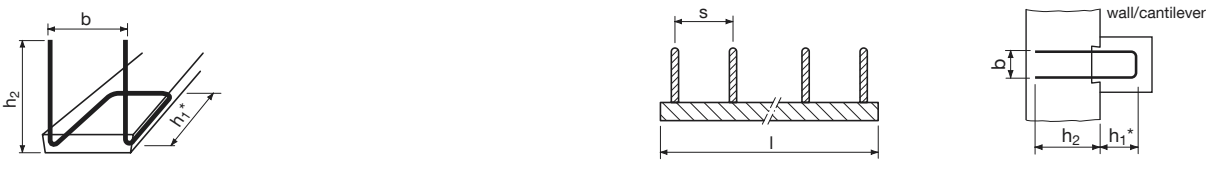

State only if required

Pos.	Steel \varnothing mm	Stirrup spacing s (cm)	Lap length h_1 (cm)	Stirrup height h_2 (cm)	Stirrup width b (cm)	Quantity pcs.	Element length l (m)	Σ lin. m	Steel case	
									Width type ____	Depth t (cm)

Stabox special design SK for cantilevers **Art. no.: STASK**

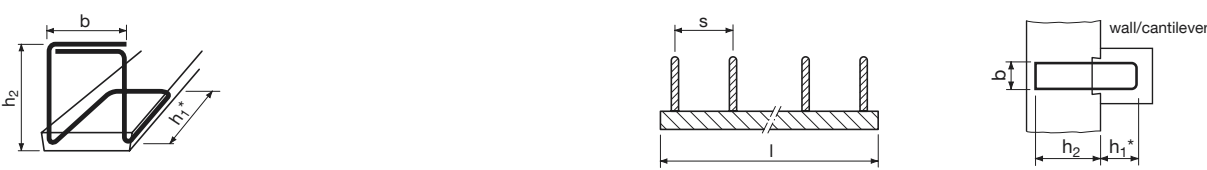

State only if required

Pos.	Steel \varnothing mm	Stirrup spacing s (cm)	Lap length h_1 (cm)	Stirrup height h_2 (cm)	Stirrup width b (cm)	Quantity pcs.	Element length l (m)	Σ lin. m	Steel case	
									Width type ____	Depth t (cm)

Stabox special design SK 1/SK 2 for cantilevers **Art. no.: STASK1/STASK2**

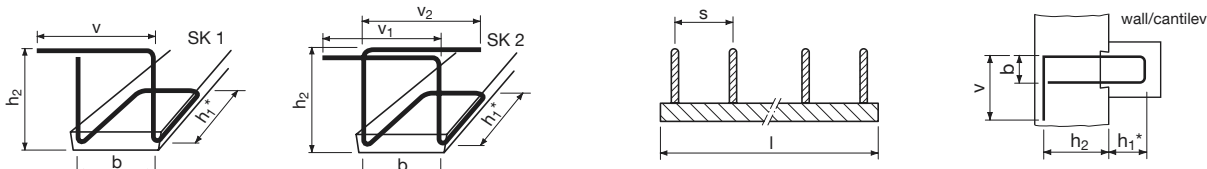

State only if required

Pos.	Steel \varnothing mm	Stirrup spacing s (cm)	Lap length h_1 (cm)	Stirrup height h_2 (cm)	Stirrup width b (cm)	Stirrup width v v_1 (cm) v_2 (cm)	Quantity pcs.	Element length l (m)	Σ lin. m	Steel case	
										Width type ____	Depth t (cm)

* Due to reasons of production and installation, h_1 may vary by 1-2 cm for cantilever Stabox types.

Stabox special design SWW deflection-resistant connection, possible in combination with type SH **Art. no.: STASWW**

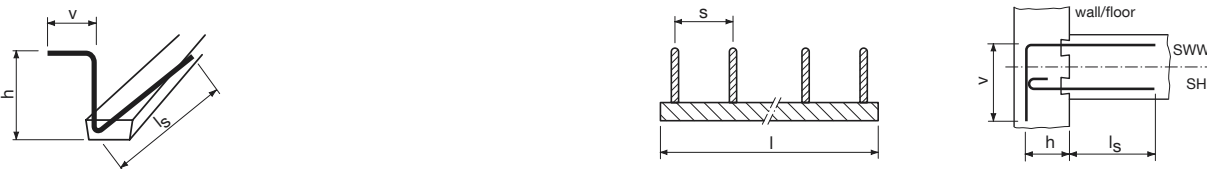

State only if required

Pos.	Steel \varnothing mm	Hook distance s (cm)	Lap length l_s (cm)	Hook height h (cm)	Hook width v (cm)	Quantity pcs.	Element length l (m)	Σ lin. m	Steel case	
									Width type ____	Depth t (cm)

Standard short elements

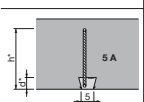
	Art. no.	Type	Element length cm	Steel-Ø mm	Stirrup spacing cm	Carton contents piece	Weight kg/pce.
	STA05A081580	5 A	80	8	15	40	1.57
	STA05A101580	5 A	80	10	15	30	2.44
	STA05A081565	5 A	65	8	15	40	1.37

Elements for use in precast work

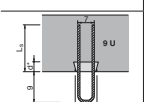
	Art. no.	Type	Steel-Ø mm	Stirrup spacing cm	Element length m	Pieces/pallet	Weight kg/pce.	Weight kg/pallet
	STA09U0815	9 U	8	15	1.25	120	4.02	502
	STA09U0820	9 U	8	20	1.25	120	3.36	423
	STA09U1015	9 U	10	15	1.25	120	6.18	762
	STA09U1020	9 U	10	20	1.25	120	4.98	618

stabox S | the rebar connection system with the dovetail profile

Lateral force perpendicular to the construction joint, joint category „interlocked“

Technical notes

Due to the optimum geometrical form of dovetail profile, in instances of lateral force perpendicular to the construction joint, the Stabox S rebar connection system fulfils the maximum requirement for a joint according to section 10.3.6. of DIN 1045-1! Maximum category: „interlocked“.

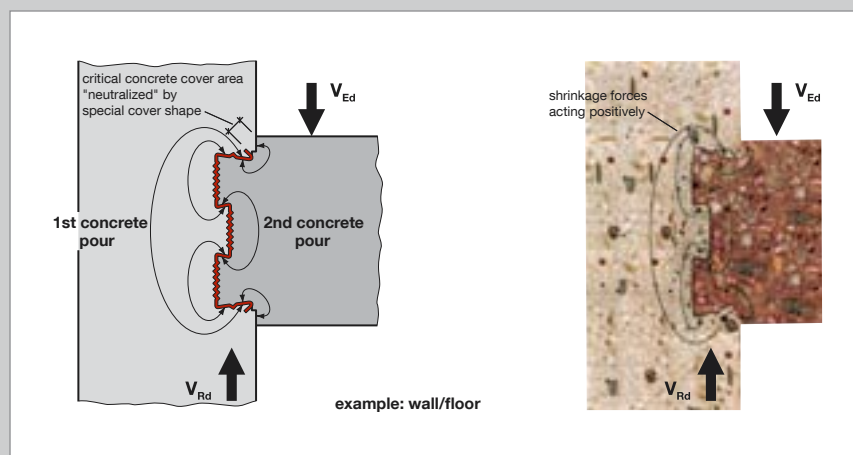

stabox T | for shearing force parallel to the construction joint „interlocked“ for maximum requirements

As a result of intensive design work on Stabox S, Stabox type T was developed especially for construction joints exposed to shearing forces parallel to the construction joint. The special very solid trapezoidal sheet steel plate of the Stabox T fulfils maximum requirements according to DIN 1045-1, section 10.3.6 parallel to joint direction.

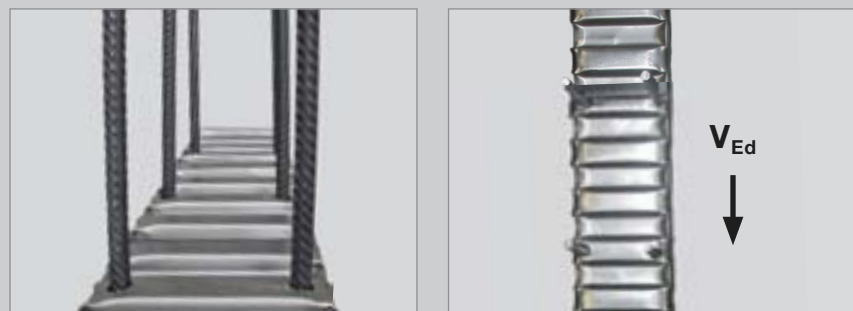

For technical advice please contact our phone number +49 (0) 94 27 / 1 89-1 89

Maximum category „interlocked“.
Prices and design versions on request.

Mauwerka

Masonry connection

Designation	Art. no.	Weight kg/pce.	Carton contents piece	Weight kg/carton	Pallet unit	Weight kg/pallet
Anchor channel 80 cm galvanised, incl. polystyrene inlay	MAU080I	0.30	150	45	600 m	245
Anchor channel 120 cm galvanised, incl. polystyrene inlay	MAU120I	0.52	-	-	600 m	280
Anchor channel 240 cm galvanised, incl. polystyrene inlay	MAU240I	1.00	-	-	600 m	270
Galvanised anchor hook	MAUWAHA	0.03	500	15	-	

The average number of hooks required is approx. 4 – 6 per lin. m, depending on the masonry used.

Structural connection between the concrete wall and the masonry

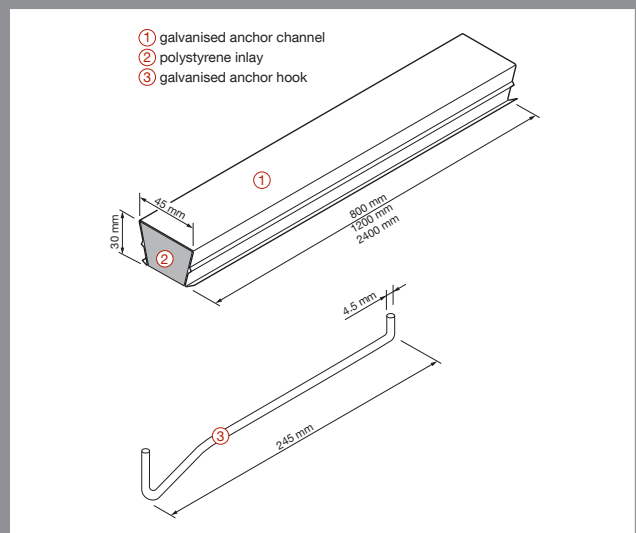
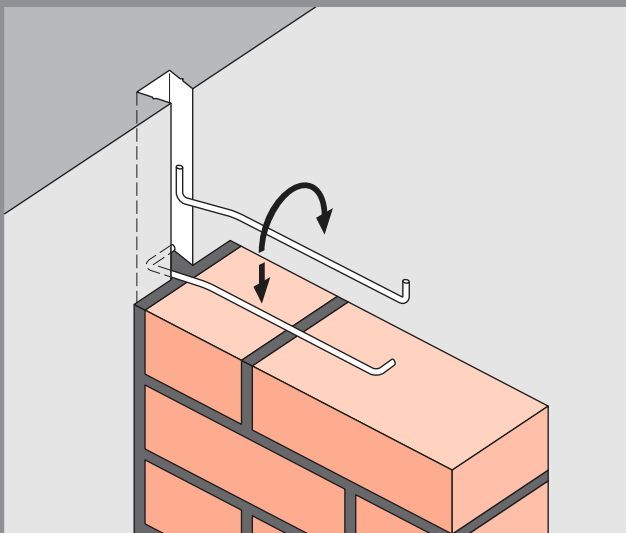

Compared with other masonry connectors Mauwerka offers the following advantages:

- Greater anchoring as a result of the wide dovetail shape and special profiling
- Infinitely variable height adjustment – measurement of the mortar joint height to fit is no longer necessary
- Any number of anchor hooks per lin. m for any brick size
- Quick and uncomplicated hook fixing



coupler | threaded steel coupler system

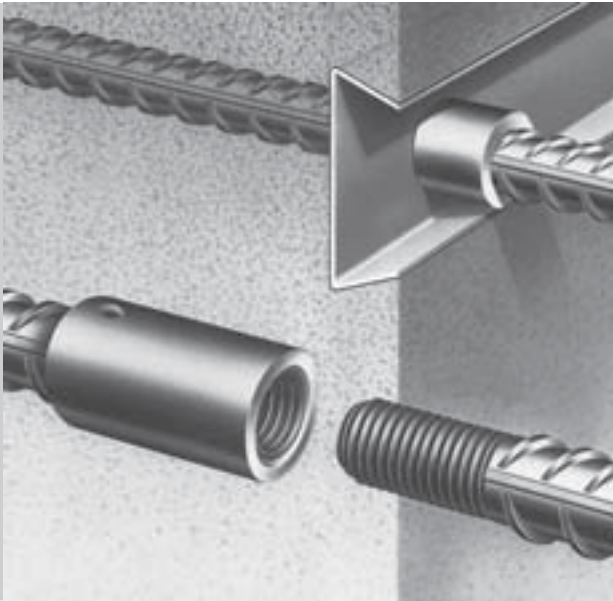

The rebar connection system with the 100% load transmission – suitable for both static and dynamic load.

- Coupler – threaded steel coupler system is a natural extension to our rebendable Stabox rebar connection system for rebars $\varnothing \geq 12$ mm
- Holds a general approval issued by the DIBt (German Institute for Structural Engineering) of Berlin, Germany, Z-1.5-100
- Steel mesh BSt 500S according to DIN 488

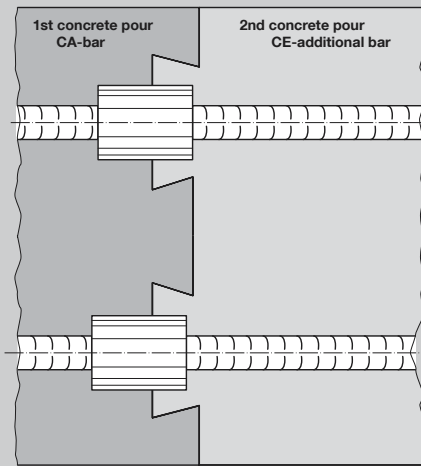
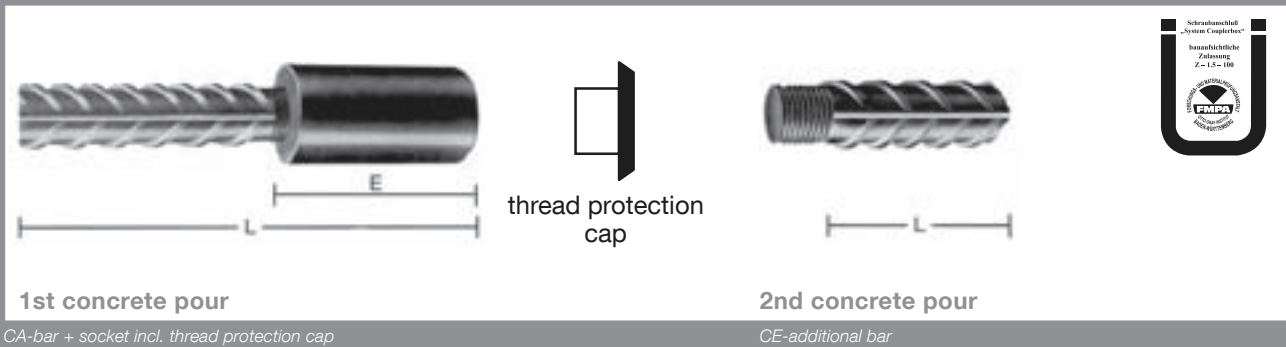

- Secure protection of the CA bars by thread protection caps
- The use of both the single box and coupler box ensures precise location of the reinforcement bars, as well as outstanding corrosion protection and additional thrust interlocking
- Simply screw the CE-bars into the box, finally tightening it to the specified torque using a torque wrench
- The benefit of an „interlocked“ joint by observing the geometry of forces to DIN 1045-1 (2001), section 10.3.6, figure 35

CA bar + socket

incl. thread protection cap for the first concrete pour

Art. no.	Diameter mm	Length mm	Sleeve E mm	Weight kg/pce.
CCA120570	12	570	40	0.56
CCA120800	12	800	40	0.77
CCA121500	12	1500	40	1.39
CCA140660	14	660	45	0.87
CCA140930	14	930	45	1.19
CCA141500	14	1500	45	1.88
CCA161020	16	1020	45	1.81
CCA161440	16	1440	45	2.48
CCA161800	16	1800	45	3.05
CCA201280	20	1280	52	3.36
CCA201800	20	1800	52	4.64
CCA202100	20	2100	52	5.38
CCA251600	25	1600	60	6.53
CCA252260	25	2260	60	9.07
CCA252600	25	2600	60	10.38
CCA281790	28	1790	65	9.15
CCA282530	28	2530	65	12.73
CCA283000	28	3000	65	15.00

CE-additional bar

for the second concrete pour

Art. no.	Diameter mm	Length mm	Weight kg/pce.
CCE120570	12	570	0.51
CCE120800	12	800	0.71
CCE121500	12	1500	1.33
CCE140660	14	660	0.80
CCE140930	14	930	1.13
CCE141500	14	1500	1.81
CCE161020	16	1020	1.62
CCE161440	16	1440	2.28
CCE161800	16	1800	2.85
CCE201280	20	1280	3.16
CCE201800	20	1800	4.45
CCE202100	20	2100	5.19
CCE251600	25	1600	6.16
CCE252260	25	2260	8.70
CCE252600	25	2600	10.01
CCE281790	28	1790	8.65
CCE282530	28	2530	12.22
CCE283000	28	3000	14.49

CAE socket and thread bar

for the first and second concrete pour

Art. no.	Diameter mm	Sleeve E mm	Tightening moment Nm	Weight kg/pce.
CCAE120570	12	40	60	1.07
CCAE120800	12	40	60	1.48
CCAE121500	12	40	60	2.72
CCAE140660	14	45	100	1.67
CCAE140930	14	45	100	2.32
CCAE141500	14	45	100	3.70
CCAE161020	16	45	100	3.43
CCAE161440	16	45	100	4.76
CCAE161800	16	45	100	5.90
CCAE201280	20	52	200	6.52
CCAE201800	20	52	200	9.09
CCAE202100	20	52	200	10.57
CCAE251600	25	60	250	12.69
CCAE252260	25	60	250	17.77
CCAE252600	25	60	250	20.39
CCAE281790	28	65	280	17.80
CCAE282530	28	65	280	24.95
CCAE283000	28	65	280	29.49

coupler | threaded steel coupler system

Fixing aids

Coupler Single box (with cover)

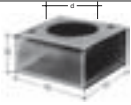
	Designation	Art. no.	Type	Diameter mm	Weight kg/pce.
	Can easily be fixed to the formwork with two nails; insert CA.	CEBOX12*	Single box Ø 12 + Ø 14	22	0.12
		CEBOX16*	Single box Ø 16 + Ø 20	33	0.12
		CEBOX25	Single box Ø 25	40	0.12
		CEBOX28	Single box Ø 28	45	0.12

* Coupler Box for bar Ø 14 corresponds to that of Ø 12, and for bar Ø 20 to that of Ø 16

Fixing aids

Coupler box (with cover)

	Designation	Art. no.	Type	Possible connection per 1.2 m element	Distance s cm	Weight kg/pce.
	The single box can be easily extended for longer applications. Bar spacing „s“ can be supplied in any dimension. Coupler Box with cover and 2 end caps. Other bar spacings „s“ can be supplied on request.	CCB1210120*	Couplerbox ø 12	12	10	0.90
		CCB1610120*	Couplerbox ø 16	12	10	0.90
		CCB2510120	Couplerbox ø 25	12	10	0.90
		CCB2810120	Couplerbox ø 28	12	10	0.90
		CCB1215120*	Couplerbox ø 12	8	15	0.90
		CCB1615120*	Couplerbox ø 16	8	15	0.90
		CCB2515120	Couplerbox ø 25	8	15	0.90
		CCB2815120	Couplerbox ø 28	8	15	0.90
		CCB1220120*	Couplerbox ø 12	6	20	0.90
		CCB1620120*	Couplerbox ø 16	6	20	0.90
		CCB2520120	Couplerbox ø 25	6	20	0.90
		CCB2820120	Couplerbox ø 28	6	20	0.90

* Coupler Box for bar Ø 14 corresponds to that of Ø 12, and for bar Ø 20 to that of Ø 16

Coupler

Torque Wrench for 12 – 28 mm

	Art. no	Weight kg/pce.
	CLDREH	5.00



Coupler threaded steel coupler system
100 % load transmission



Special types are manufactured to your requirements. Please get in contact with our technical advisory service.

Type CA

Art. no. CCA12*SONL

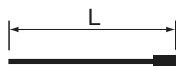

Type CE

Art. no. CCE12*SONL

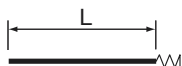

Type ECA

Art. no. CECA12*



Type DCA

Art. no. CSDCA



Type DCE

Art. no. CSDCE



Type WCA

Art. no. CSWCA

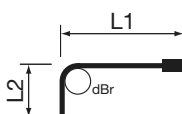

Type WCASB

Art. no. CSWCASB

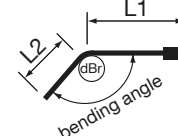

Type DCAW

Art. no. CSDCAW

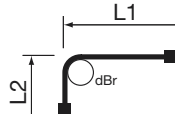

Type WCE

Art. no. CSWCE

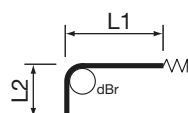

Type DWCA

Art. no. CSDWCA

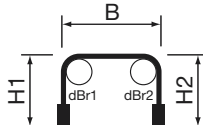

Type WCAG

Art. no. CSWCAG

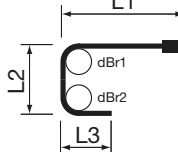

Type WWCA

Art. no. CSWWCA

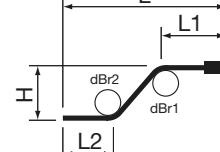

Type WWECA

Art. no. CSWWECA

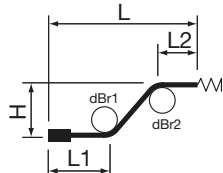

Type WWCE

Art. no. CSWWCE

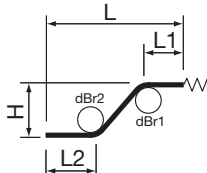

Type CALG

Art. no. CSCALG

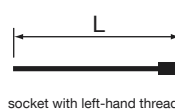

Type WCALG

Art. no. CSWCALG

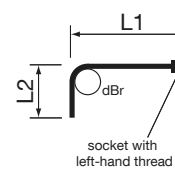

Type CA-APG

Art. no. CSCAAPG

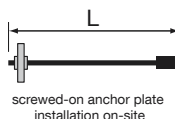

Type CA-APS

Art. no. CSCAAPS

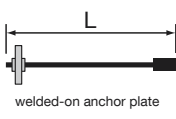

Type CE-APG

Art. no. CSCEAPG

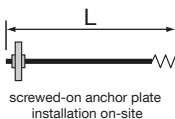

Type CE-APS

Art. no. CSCEAPS

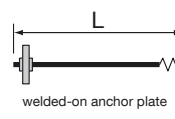

* varying according to bar diameter 12, 14, ...

- Special types are cost-efficiently manufactured to your requirements. Please enquire for delivery time.
- If there is a requirement at very short notice, it is also possible to manufacture these special types by welding reinforcement steel onto

standard types (flash butt welding procedure to DIN 4099 which does not reduce the working stress of the steel).

- Ø 32 mm and 40 mm can be supplied. These sizes do not carry general approval of the construc-

tion supervising authorities.

Please enquire for prices of the special types.

The production of special accessories is carried out using the same quality criteria as for the standard ranges. However, our certification does not cover the production of special accessories. Structural analysis verification must be carried out in each specific application.

Adapter connection

The adapter should be used when rebars with bent legs are required or are unable to be screwed in.

System description



Socket with right-hand/left-hand thread (designation „LG“ for left-hand thread)



Adapter for connecting left-hand threaded socket to standard right-hand threaded socket



Standard right-hand threaded socket

Application example

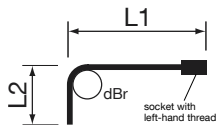

For adapter connection in one concrete pour, a socket with right-hand/left-hand thread must be used.



Screwing the adapter brings the rebars together up to the limit stop. A locknut is used for fixing the assembly.

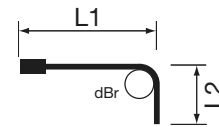

A standard right-hand threaded socket is fixed to the second rebar.

Coupler

Special accessories – adapter

Art. no.	Diameter mm
CAGRELI12	12
CAGRELI14	14
CAGRELI16	16
CAGRELI20	20
CAGRELI25	25
CAGRELI28	28

Anchor plate made of ST 37 and hexagon nut

for threaded steel bars M12 – M28

Designation	Art. no.	Thread size of nut	Anchor plate dimensions mm
Price per set of hexagonal nut, anchor plate and counternut. Price for threaded steel bar on request.	CAPLGSCHR12	M12	40 x 40 x 10
	CAPLGSCHR14	M14	50 x 50 x 10
	CAPLGSCHR16	M16	60 x 60 x 12
	CAPLGSCHR20	M20	70 x 70 x 16
	CAPLGSCHR25	M25	90 x 90 x 18
	CAPLGSCHR28	M28	100 x 100 x 20

Anchor plate made of ST 37, welded-on

Designation	Art. no.	Structural steel diameter mm	Anchor plate dimensions mm
Price per welded on anchor plate; Price for reinforcement bar cut to length on request	CAPLGSCHW12	12	40 x 40 x 10
	CAPLGSCHW14	14	50 x 50 x 10
	CAPLGSCHW16	16	60 x 60 x 12
	CAPLGSCHW20	20	70 x 70 x 16
	CAPLGSCHW25	25	90 x 90 x 18
	CAPLGSCHW28	28	100 x 100 x 20

Certificate of welding not available. Manufacturing to customer specification is by prior consultation.

The Titan transverse force dowel system is intended for the transmission of transverse forces under mainly static loading at expansion joints in reinforced concrete members.

The joint formation and distribution of forces in the concrete must be designed and dimensioned by a structural engineer.

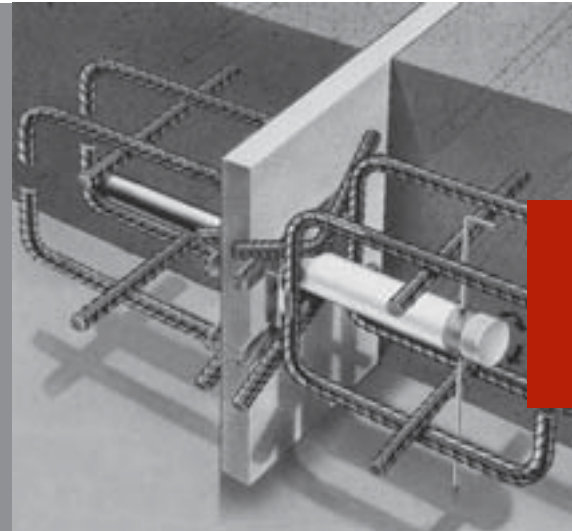

Titan

Transverse force dowels galvanised or made of stainless steel incl. fixing materials

	Art. no.	Type	Steel	Diameter mm	Length L mm	Weight kg/pce.
	TQDG201	G-20-1	St 37	20	320	0.96
	TQDG200	G-20-0	high-strength	20	320	0.96
	TQDG220	G-22-0	high-strength	22	340	1.19
	TQDG250	G-25-0	high-strength	25	390	1.69
	TQDG300	G-30-0	high-strength	30	470	2.83
	TQDG400	G-40-0	high-strength	40	570	5.93
	TQDI200	I-20-0	stainless	20	320	0.96
	TQDI220	I-22-0	stainless	22	340	1.19
	TQDI250	I-25-0	stainless	25	390	1.69
	TQDI300	I-30-0	stainless	30	470	2.83
	TQDI400	I-40-0	stainless	40	570	5.93

Titan

Dowels with special sliding sleeves for two-dimensional movement

	Art. no.	Type	Steel	Diameter mm	Length L mm	Weight kg/pce.
	TQDGS201	G-20-1	St 37	20	320	0.96
	TQDGS200	G-20-0	high-strength	20	320	0.96
	TQDGS220	G-22-0	high-strength	22	340	1.19
	TQDGS250	G-25-0	high-strength	25	390	1.69
	TQDGS300	G-30-0	high-strength	30	470	2.83
	TQDGS400	G-40-0	high-strength	40	570	5.93
	TQDIS200	I-20-0	stainless	20	320	0.96
	TQDIS220	I-22-0	stainless	22	340	1.19
	TQDIS250	I-25-0	stainless	25	390	1.69
	TQDIS300	I-30-0	stainless	30	470	2.83
	TQDIS400	I-40-0	stainless	40	570	5.93

Titan accessories

	Designation	Art. no.	Diameter mm	Weight kg/pce.
2 x	Reinforcing cages type N, for floor/floor connection, ready-made incl. fixing materials for concrete pour II	TQDB20	20	2.36
		TQDB22	22	2.36
		TQDB25	25	2.44
		TQDB30	30	4.23
		TQDB40	40	4.23
1 x + 1 x	Special reinforcing cages type S, for wall/floor connection, ready-made incl. fixing materials for concrete pour II	TQDBW20	20	2.36
		TQDBW22	22	2.36
		TQDBW25	25	2.44
		TQDBW30	30	4.23
		TQDBW40	40	4.23

Egcdorn is a high-performance corrosion-proof transverse force dowel which transfers maximum loads whilst having a minimum component thickness. Using the Egcdorn, extensive formwork for expansion joints is not necessary. The unique corrosion protection system and the use of high-quality materials guarantee highest safety and quality.

The Egcdorn has a DIBt (Deutsches Institut für Bautechnik Berlin = German Institute for Structural Engineering Berlin) approval.

Expansion joints are construction measures that compensate for deformations caused by physical changes (thermal expansion, shrinking, material creep) typical in building constructions. This is the primary application purpose of the Egcdorn.

This type of joint, which is subject to transverse forces, can now be accomplished with the highly sophisticated egcodorn transverse force dowel.

- Basis of calculation and load values acc. to Eurocode
- Basis of calculation and load values acc. to application DIBt Germany

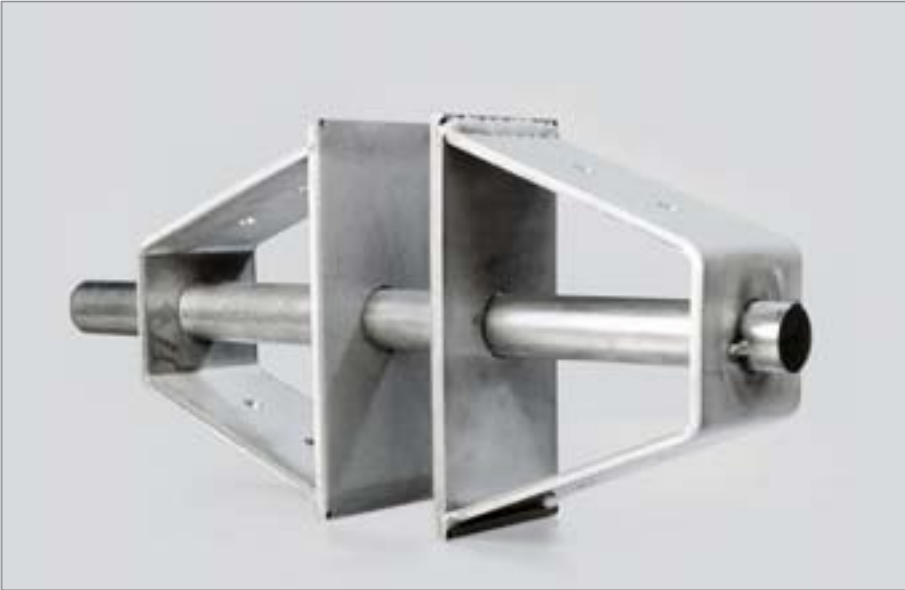

**Egcdorn:
the stainless steel dowel system**

- Optimum load transmission to concrete
- Transfers maximum loads whilst having a minimal component thickness
- Easy joint production
- Highest corrosion protection due to high-quality stainless steel
- Absorption of longitudinal/transverse movements
- Simple installation
- Cost-effective
- Fire protection F120

Special versions can also be supplied, such as:

- Complete formwork elements combining Egcdorn and Stremaform
- Customised solutions for absorption of dynamic expansion joint loads



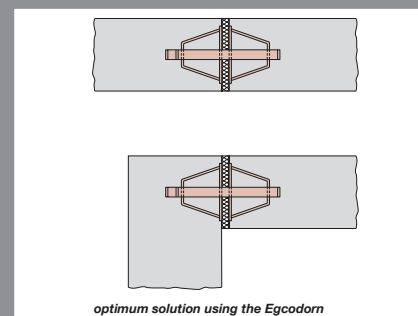
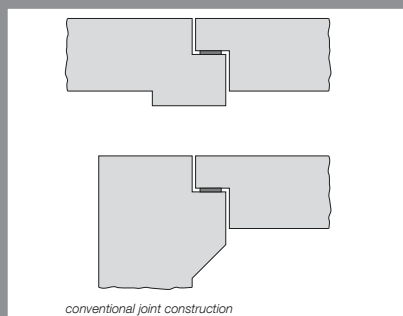

Complete formwork element combining Egcdorn and Stremaform pre-installed and delivered onto site for expansion joint construction

Examples of use



Egcdorn

Transverse force dowels for very high static loads with DIBT approval and load values acc. to Eurocode

	Designation	Art. no.	Type	Weight kg/pce.
	Approved for transverse load transmission, allows lengthwise movement	DNB050	DNB50	3.02
		DNB070	DNB70	4.53
		DNB095	DNB95	6.63
		DNB120	DNB120	9.00
		DNB150	DNB150	13.48
		DNB210	DNB210	19.66
		DNB300	DNB300	34.59
		DNB350	DNB350	38.36
	DNBSON*	DNBSON	-	
	Approved for transverse load transmission, allows lengthwise and lateral movement	DQB050	DQB50	4.27
		DQB070	DQB70	6.44
		DQB095	DQB95	8.62
		DQB120	DQB120	11.21
		DQB150	DQB150	16.11
		DQB210	DQB210	24.19
		DQB300	DQB300	37.89
		DQB350	DQB350	45.59
	DQBSON*	DQBSON	-	

* Special dimensions;

For special applications, complete formwork elements combining both Egcodorn and Stremaform, please contact our technical advisory service. Fixing instructions, design tables and calculation instructions for Egcodorn are in our Egcodorn brochure.

Egcdorn

Transverse force dowels for transverse force transmission and dynamic loads with DIBT approval Z-15.7-112

	Designation	Art. no.	Type	Weight kg/pce.
	Approved for both transverse load transmission and for dynamic loads, allows lengthwise movement	EDND20	DND20	2.62
		EDND22	DND22	3.19
		EDND25	DND25	4.92
		EDND28	DND28	7.56
		EDND30	DND30	8.42
		EDND35	DND35	14.19
		EDND40	DND40	20.55
			EDNDSON*	DNDSON

* Special dimensions;

For specific applications using complete formwork elements which combine Egcodorn and Stremaform as well as for applications requiring additional transmission of dynamic loads within the joint please get in contact with our technical advisory service.

Egcdorn

Fire protection seal corresponding to fire resistance class F120

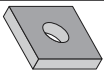
	Designation	Art. no.
	Please specify Egcodorn or Egcodübel type required. For standard dimensions, please specify joint width. Special dimensions are manufactured to your requirements.	EDBRAND

We also produce complete joint solutions to fire resistance class F90, please contact our technical advisory service.

For over 40 years FRANK has been well known for quality and customer-oriented solutions.



Egcodübel with sleeve

for expansion joints

	Designation	Art. no.	Type	Dowel diameter mm	Length of dowel mm
	Stainless-steel dowel (DM), material: HF, incl. circular stainless steel sliding sleeve (HI), for transmission of lengthwise movement	EDMH20*	DMHI20HF	20	340
		EDMH22*	DMHI22HF	22	350
		EDMH27*	DMHI27HF	27	360
		EDMH30*	DMHI30HF	30	400
		EDMH37*	DMHI37HF	37	470
	Stainless-steel dowel (DM), material: S 355, incl. circular stainless-steel sliding sleeve (HI), for transmission of lengthwise movement	EDMH20*	DMHI20	20	300
		EDMH22*	DMHI22	22	300
		EDMH27*	DMHI27	27	300
		EDMH30*	DMHI30	30	350
	Stainless-steel dowel (DM), material: HF, incl. rectangular stainless-steel sliding sleeve (HQI), for transmission of lengthwise and lateral movement	EDMH20*	DMHQI20HF	20	340
		EDMH22*	DMHQI22HF	22	350
		EDMH27*	DMHQI27HF	27	360
		EDMH30*	DMHQI30HF	30	400
		EDMH37*	DMHQI37HF	37	470
	Stainless-steel dowel (DM), material: S 355, incl. rectangular stainless-steel sliding sleeve for transmission of lengthwise and lateral movement	EDMH20*	DMHQI20	20	300
		EDMH22*	DMHQI22	22	300
		EDMH27*	DMHQI27	27	300
		EDMH30*	DMHQI30	30	350
	Stainless-steel dowel (DM), material: high-strength (HF), incl. circular plastic sliding sleeve (H), for max. dowel length 500 mm and for transmission of lengthwise movement	EDMH20*	DMH20HF	20	340
		EDMH22*	DMH22HF	22	350
		EDMH27*	DMH27HF	27	360
		EDMH30*	DMH30HF	30	400
	Stainless steel dowel (DM), material S 355, incl. circular plastic sliding sleeve (H), for max. dowel length 500 mm and transmission of lengthwise movement	EDMH20*	DMH20	20	300
		EDMH22*	DMH22	22	300
		EDMH27*	DMH27	27	300
		EDMH30*	DMH30	30	350
	Galvanised dowel (DFA), material: high-strength (HF), incl. circular plastic sliding sleeve (H), for max. dowel length 500 mm, for transmission of lengthwise movement	TDFAH20	DFAH20HF	20	340
		TDFAH22	DFAH22HF	22	350
		TDFAH25	DFAH25HF	25	360
		TDFAH30	DFAH30HF	30	400
	Galvanised dowel (DFA), material: S 355, incl. circular plastic sliding sleeve (H), for max. dowel length 500 mm, for transmission of lengthwise movement	TDFAH20	DFAH20	20	300
		TDFAH22	DFAH22	22	300
		TDFAH25	DFAH25	25	300
		TDFAH30	DFAH30	30	350
	Galvanised dowel (DFA), material: S 235, incl. grey plastic sliding sleeve (H), for transmission of lengthwise movement	TDFAH20	DFAH20	20	according to data given
		TDFAH25	DFAH25	25	according to data given

* Dowel with stainless steel casing; for Ø 20 mm the dowel is entirely made of stainless steel. The diameter indication for Egcodübel with stainless steel jackets refers to the external diameter. The diameter of the steel core is the external diameter minus 2 mm.

Delivery times on request;

Fixing instructions, design tables and calculation instructions is in the Egcodübel brochure.

For joints rated to fire resistance class F120 see product list page 45.

Ask for our free-of-charge brochure

„Egcodorn & Egcodübel“

under the phone number +49 (0) 94 27 / 1 89-0



Egcodübel

for expansion joints

	Designation	Art. no.	Type	Dowel diameter mm	Length of dowel mm
	Dowel with stainless steel sleeve and high-strength steel core	EDM20340*	DM20HF	20	340
		EDM22350*	DM22HF	22	350
		EDM27360*	DM27HF	27	360
		EDM30400*	DM30HF	30	400
		EDM37470*	DM37HF	37	470
	Dowel with stainless-steel sleeve, S 355 steel	EDM20300*	DM20	20	300
		EDM22300*	DM22	22	300
		EDM27300*	DM27	27	300
		EDM30350*	DM30	30	350
	Special-type dowels	EDMSONDER	DMØ	according to data given	
	Dowel – galvanized, high-strength steel	TDFA20340	DFA20HF	20	340
		TDFA22350	DFA22HF	22	350
		TDFA25360	DFA25HF	25	360
		TDFA30400	DFA30HF	30	400
	Dowel – galvanized, S 355	TDFA20300	DFA20	20	300
		TDFA22300	DFA22	22	300
		TDFA25300	DFA25	25	300
		TDFA30350	DFA30	30	350
	Dowel – galvanized, S 235	TQG18500	TQG18	18	500
		TQG20500	TQG20	20	500
		TQG22500	TQG22	22	500
		TQG25500	TQG25	25	500
		TQG28500	TQG28	28	500
	Dowel – galvanized, S 355; semi-clad with elastic material, expansion cap for one-dimensional movement	TDFAHB20500	DFAHB20	20	500
		TDFAHB22500	DFAHB22	22	500
		TDFAHB25500	DFAHB25	25	500
	Dowel – galvanized, S 235; semi-clad with elastic material, expansion cap for one-dimensional movement	TQGHB18500	TQGHB18	18	500
		TQGHB20500	TQGHB20	20	500
		TQGHB22500	TQGHB22	22	500
		TQGHB25500	TQGHB25	25	500
		TQGHB28500	TQGHB28	28	500

* Dowel with stainless steel casing; for Ø 20 mm the dowel is entirely made of stainless steel. The diameter indication for Egcodübel with stainless steel jackets refers to the external diameter. The diameter of the steel core is the external diameter minus 2 mm.

Delivery times on request;

For joints rated to fire resistance class F120 see product list page 45.

Dowels

for construction joints

	Designation	Art. no.	Type	Dowel diameter mm	Length of dowel mm
	Dowel – S 235 black, with full plastic coating	TQDVOLL25	TQDVOLL25	25	500
	Dowel, BSt 500 S, ribbed steel dowel, epoxy coated	TQD2A	2-A	20	500
		TQD2B	2-B	25	500

Delivery times on request

Corrosion-resistant tie bar

	Designation	Art. no.	Bar diameter mm	Length of tensible anchor mm
	Tie bar, material BSt 500 S with stainless steel sleeve, sleeve length 200 mm	TDZ12	12	980
		TDZ14	14	1100
		TDZ16	16	1240
		TDZ20	20	1500

Mitterweg 1
94339 Leiblfing · Germany
Phone +49 (0) 94 27 / 1 89-0 · Fax +49 (0) 94 27 / 15 88
info@maxfrank.com
www.maxfrank.com



PECA-Verbundtechnik GmbH

Industriestraße 4-8
96332 Pressig
Germany
Phone +49(0)92 65/951 -0
Fax +49(0)92 65/951 -20
www.peca.de
info@peca.de

Frank Slovakia, S.r.o.

ul. J. Haška 1
94901 Nitra
Slovakia
Phone +421 (0)37/6522885
Fax +421 (0)37/6554133
www.sk.maxfrank.com
info@sk.maxfrank.com

Max Frank Limited

Whittle Road, Meir
Stoke-on-Trent, ST3 7HF
United Kingdom
Phone +44(0)1782 598041
Fax +44(0)1782 315056
www.maxfrank.co.uk
info@maxfrank.co.uk

Max Frank Nederland bv

Rootven 6
5531 MB Bladel
Netherlands
Phone +31(0)497 383538
Fax +31(0)497 384820
www.maxfrank.nl
info@maxfrank.nl

EGCO AG

Industriestrasse 100
3178 Bössingen
Switzerland
Phone +41 (0)31/7 405555
Fax +41 (0)31/7 405556
www.egco.ch
info@egco.ch

**Max Frank Oddział
w Polsce**

ul. Łopuszańska 36
02-220 Warszawa
Poland
Phone +48(0)22/577 0581
Fax +48(0)22/8462737
www.pl.maxfrank.com
info@pl.maxfrank.com

Max Frank (Canada) Ltd.

49 Maplecrest Lane
Brantford, Ontario N3R 7TG
Canada
Phone +1-519-759-3854
Fax +1-519-759-3854
www.ca.maxfrank.com
info@ca.maxfrank.com

Max Frank GesmbH

Weinburg/Waasen
3200 Obergrafendorf
Austria
Phone +43(0)27 47/2378-0
Fax +43(0)27 47/237885
www.maxfrank.at
info@maxfrank.at

Max Frank Kft.

Malomkő utca 7,
A lépcsőház 2. emelet
2040 Budaörs
Hungary
Phone +36 23 500 182
Fax +36 23 500 183
www.hu.maxfrank.com
info@hu.maxfrank.com

Max Frank Middle East

P.O.Box 121430
Dubai
UAE
Phone +971 4 609 1700
Fax +971 4 609 1701
www.ae.maxfrank.com
info@ae.maxfrank.com

Frank Italy S.r.l.

Zona Industriale Molini 6
39032 Campo Tures
Italy
Phone +39(0)4 74 / 65 90 08
Fax +39(0)4 74 / 65 90 18
www.frank-italy.com
info@frank-italy.com

Max Frank Ukraine

Luteranska 16, Office 9
01024 Kiev
Ukraine
Phone +380 44 2 79 79 61
Fax +380 44 2 79 79 61
www.ua.maxfrank.com
info@ua.maxfrank.com

Max Frank Pte Ltd

222 Tagore Lane
#01-01, TG Building
Singapore 787603
Phone +65 6451 7063
Fax +65 6451 4008
www.sg.maxfrank.com
info@sg.maxfrank.com

